Modelling and Maximum Power Point Tracking Algorithms for Photovoltaic System

Asim Ahmad Malik

Abstract

This paper focuses on the development of a simplified mathematical model of Photovoltaic (PV) system which can be representative of a cell, module or array for easy use on simulation platforms. The implementation of Maximum Power Point Tracking (MPPT) algorithms on Photovoltaic systems is also presented to track the operating point at which maximum power can be coerced from such systems under varying environmental conditions. A 62W PV panel is simulated in MATLAB/Simulink taking varying irradiation and cell temperature into consideration. Output current and power characteristics of the developed model are simulated and studied. A simulation based comparative study between the Perturb and Observe (P&O) and Incremental Conductance (InC) based MPPT algorithms is also presented.

Copyright © 2020 International Journals of Multidisciplinary Research Academy. All rights reserved.

Keywords:

MPPT;
Photovoltaic (PV) system;
Perturb and Observe (P&O);
Incremental Conductance;
MATLAB/Simulink.

Author's correspondence:

Asim Ahmad Malik,
M.Tech Scholar (Power System), Department of Electrical Engineering
RIMT University, Mandi Gobindgarh, Punjab - India

1. Introduction

Renewable energy can be considered as one of the fundamental premises for building a sustainable global society. With growing concerns about fossil fuel deficits, rising oil prices, global warming and damage to environment and ecosystem, the need for developing alternative energy resources with high efficiency and low emission arises. Due to the ubiquity, availability, and sustainability of solar radiant energy, energy through the photovoltaic (PV) effect can be considered the most important and prerequisite sustainable resource among renewable energy resources. Regardless of sunlight's intermittency, solar power is widely available and cost-free. When exposed to solar radiation, a Photovoltaic (PV) system can generate direct current (DC) electricity without any environmental impact and pollution. This has become a popular choice for electric power generation in remote areas as well as in places where power generation in conventional ways is not practical. However, the efficiency of such a system is as low as 33%. Therefore to optimize the energy conversion efficiency and to reduce costs, it becomes important to use effective techniques.

Using the PV effect, a PV device directly transforms solar energy into electricity. The basic device of a PV system is a solar cell. Though the output of such a cell depends on many factors like cell type, cell size etc, a typical solar cell can generate an open circuit voltage of about 0.5V which is quite low, hence the need for fusion/combination arises. Solar cells can be grouped together to form modules or even bigger arrays. These modules or arrays can be further connected in series or parallel to form large PV systems capable of fulfilling a particular load demand. However, due to the non-linear nature of PV systems, there is only one Maximum Power Point (MPP) in a particular environment at which such a system can generate maximum power. With the change in solar irradiation and cell temperature, this Maximum Power Point (MPP) continues to change accordingly. Hence, the system must always operate at the Maximum Power Point, which reflects the maximum energy that can be generated from the PV system, for optimal operation. To obtain this value, MPPT systems must be used to automatically allow the MPP to be reached. A wide range of MPPT techniques have been developed for this and implemented. Among the various, the most commonly used techniques viz. Perturb and Observe (P&O) technique and the Incremental Conductance (InC) technique have been presented in the later section of this paper.

Essentially, solar cell is a p-n junction fabricated in a thin wafer or layer of semiconductor that has been exposed to electromagnetic radiation. Its working is based on the basic principle of Photovoltaic effect. When such a cell is exposed to radiation, photons with energy greater than the band-gap energy of the semiconductor are absorbed and create some electron-hole pairs proportional to the incident irradiation. Such carriers are swept apart under the influence of internal electric fields of the p-n junction and hence create a photocurrent that is directly proportional to solar insolation. Obviously, the PV system has non-linear I-V and P-V characteristics that differ with radiant strength and cell temperature as mentioned.

2. Mathematical Modelling of Photovoltaic (PV) System

Equivalent circuit models define the entire I-V characteristics of a solar cell, module or array as a continuous function for a given set of operating conditions. These models are used for implementing the various MPPT techniques practically. This paper deals with the single diode model of solar cell which is explained further. It consists of a photocurrent source, a diode, a parallel resistor expressing a leakage current and a series resistor describing an internal resistance to the flow of current. The model is derived from basic form as a typical current source and approaches to the final equivalent circuit of the model starting from the equivalent circuit of an ideal solar cell.

The equivalent circuit of an ideal solar cell is a current source in parallel with single diode, in case of a single diode model. The configuration is shown below:

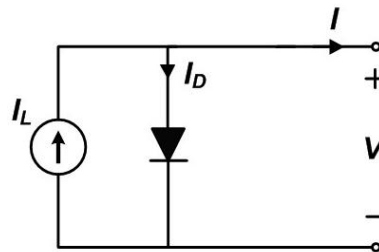

Figure 2.1: Equivalent circuit of an ideal solar cell.

The equation for this equivalent circuit is formulated using Kirchoff's Current Law:

$$I = I_L - I_D$$

$$I = I_L - I_0 \left[\exp\left(\frac{qV}{nkT}\right) - 1 \right]$$

where;

I is the output current, I_L is the photocurrent (current generated by incident light), I_D is the diode current given by the Shockley diode equation, I_0 is the reverse saturation current, q is the charge of an electron which is equal to $1.602176634 \times 10^{-19}$ C, V is the voltage across the diode, n is the diode ideality factor, k is the Boltzmann's constant and is equal to $1.38064903 \times 10^{-23}$ J/K, T is the actual temperature in Kelvin.

and;

$$V_T = \left(\frac{kT}{q}\right)$$

where;

V_T is the thermal voltage.

The equivalent circuit of solar cell with a series resistance representing the ohmic voltage drop at the contacts and through the layers of materials is also shown below. The value of this series resistance can vary under different conditions of illuminations.

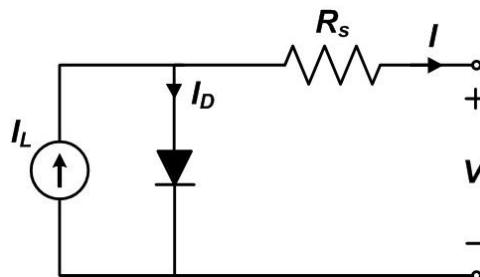

Figure 2.2: Equivalent circuit of a solar cell with series resistance.

$$I = I_L - I_0 \left\{ \exp \left[\frac{q}{nkT} (V + IR_s) \right] - 1 \right\}$$

where;

R_s is the series resistance.

The practical equivalent circuit of a solar cell can be illustrated by placing a resistor, expressing a leakage current parallel to the diode in addition to the series resistance as shown below:

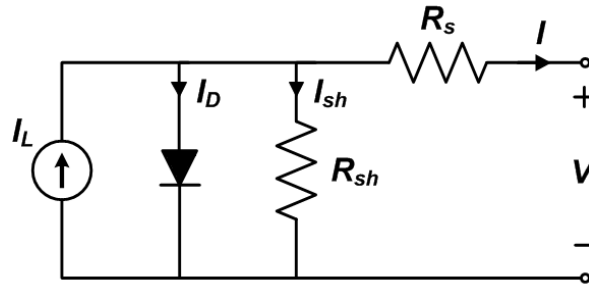

Figure 2.3: Equivalent circuit of a practical solar cell with series and parallel resistances.

Based on the equivalent circuit, the current relationship can be expressed by applying K.C.L as;

$$\begin{aligned} I_L &= I_D + I_{sh} + I \\ I &= I_L - I_D - I_{sh} \end{aligned} \quad (2.1)$$

$$I_D = I_0 \left\{ \exp \left[\frac{q}{nkT} (V + IR_s) \right] - 1 \right\} \quad (2.2)$$

$$I_{sh} = \left(\frac{V + IR_s}{R_{sh}} \right) \quad (2.3)$$

Substituting the values of (2.2) and (2.3) in equation (2.1), we get;

$$I = I_L - I_0 \left\{ \exp \left[\frac{q}{nkT} (V + IR_s) \right] - 1 \right\} - \left(\frac{V + IR_s}{R_{sh}} \right)$$

where;

R_{sh} is the shunt resistance.

The I-V characteristics of the solar model depend on the external influences such as irradiation level and temperature as well in addition to the internal characteristics.

The photocurrent I_L which depends on the irradiation and temperature can be further expressed as;

$$I_L = \left[I_{sc} + K_i (T - T_{Ref}) \right] \frac{G}{G_{Ref}}$$

where;

I_{sc} is the cell's short-circuit current at standard test conditions (25°C and 1000W/m^2), K_i is the cell's short-circuit current temperature coefficient, T is the actual temperature in Kelvin, T_{Ref} is the cell's reference temperature in Kelvin, G is the actual solar irradiation in W/m^2 , G_{Ref} is the reference/nominal solar irradiation in W/m^2 .

The reverse saturation current I_0 and its dependence on temperature may be expressed as;

$$I_0 = I_{rs} \left(\frac{T}{T_{Ref}} \right)^3 \exp \left[\frac{qE_g}{nk} \left(\frac{1}{T_{Ref}} - \frac{1}{T} \right) \right]$$

where;

I_{rs} is the reverse saturation current at standard test conditions (25°C and 1000W/m^2), E_g is the band gap energy of semiconductor.

The standard reverse saturation current can be further expressed as;

$$I_{rs} = \frac{I_{sc}}{\exp\left(\frac{qV_{oc}}{nkT}\right) - 1}$$

where;

V_{oc} is the open circuit voltage.

As the power generated by a single photovoltaic cell is very low as discussed earlier, a combination of cells are used in both series and parallel to fulfill the desired requirement. This grid of photovoltaic cells so formed is known as a photovoltaic array. The equivalent circuit and its constituent equation is given below:

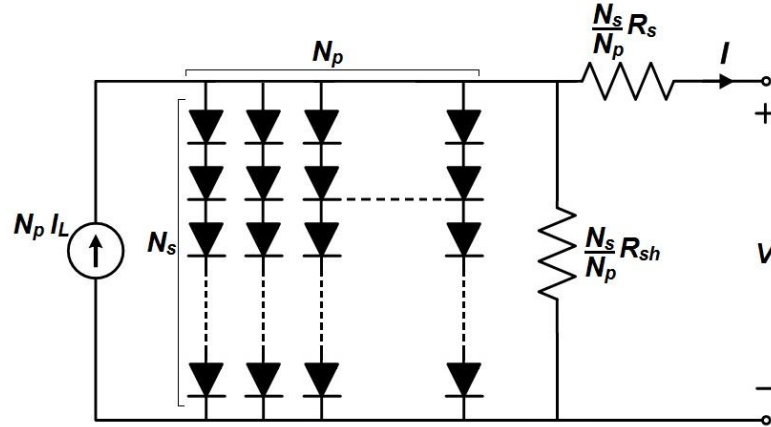

Figure 2.4: Equivalent circuit of a solar array.

$$I = N_p I_L - N_p I_0 \left\{ \exp \left[\frac{q \left(\frac{V}{N_s} + \frac{I R_s}{N_p} \right)}{nkT} \right] - 1 \right\} - \left(\frac{V N_p + I R_s}{R_{sh}} \right)$$

$$I = N_p I_L - N_p I_0 \left[\exp \left(\frac{V N_p + I R_s N_s}{N_s N_p n V_T} \right) - 1 \right] - \left(\frac{V N_p + I R_s N_s}{N_s R_{sh}} \right)$$

where;

N_s is the number of cells in series, N_p is the number of cells in parallel, $V_T = kT/q$ is the thermal voltage.

The photovoltaic efficiency is insensitive to a small variation in shunt resistance R_{sh} but is much sensitive to any variation in the series resistance R_s . For a photovoltaic array or module the series resistance hence becomes more important and the shunt resistance approaches infinity which can be assumed to be open. The mathematical model in that case can be expressed as:

$$I = N_p I_L - N_p I_0 \left[\exp \left(\frac{V N_p + I R_s N_s}{N_s N_p n V_T} \right) - 1 \right]$$

In addition, maximum power produced by the photovoltaic system can be expressed as:

$$P_{max} = V_{max} I_{max} = \gamma V_{oc} I_{sc}$$

where;

V_{max} is the terminal voltage of PV array at MPP, I_{max} is the output current of PV array at MPP, γ is the fill factor which is a measure of cell quality.

3. Simulation Results

A 62W PV panel is simulated in MATLAB/Simulink for the specifications provided in the table below:

Table 1: PV panel Specifications

Maximum Power	62W
Voltage	17V
Current	3.5A
Short Circuit Current	3.8A
Open Circuit Voltage	21.1V

The Single Diode Model is used to simulate the 62W PV Array using MATLAB environment. Figure 3.1 and Figure 3.2 display that the output current and voltage of the PV array increases with increase in solar irradiation level from 200W/m^2 to 1000W/m^2 . Figure 3.3 and Figure 3.4 display a linear decrease in panel voltage and current caused by an increase in surrounding temperature.

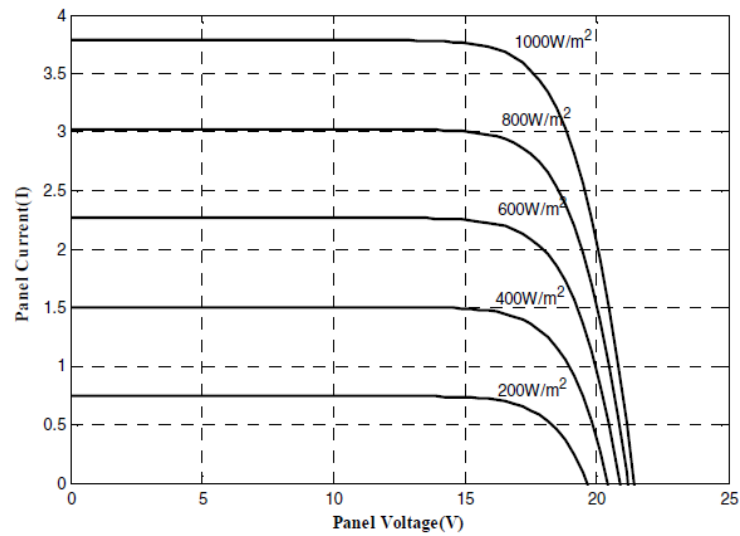
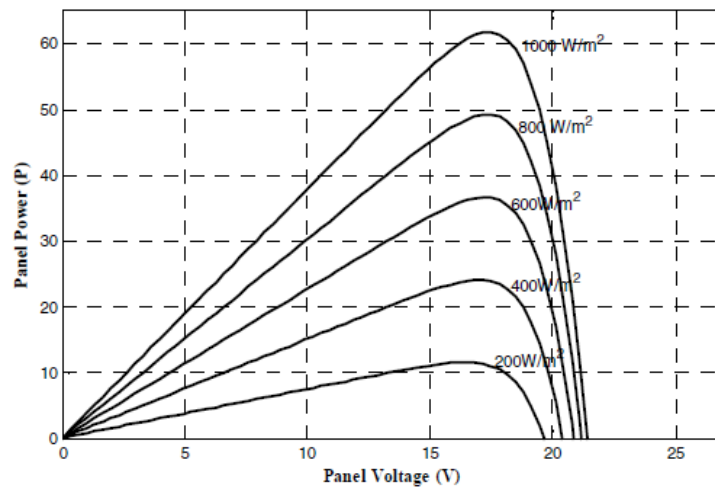
**Figure 3.1:** I-V curve for different irradiation levels.**Figure 3.2:** P-V curve for different irradiation levels.

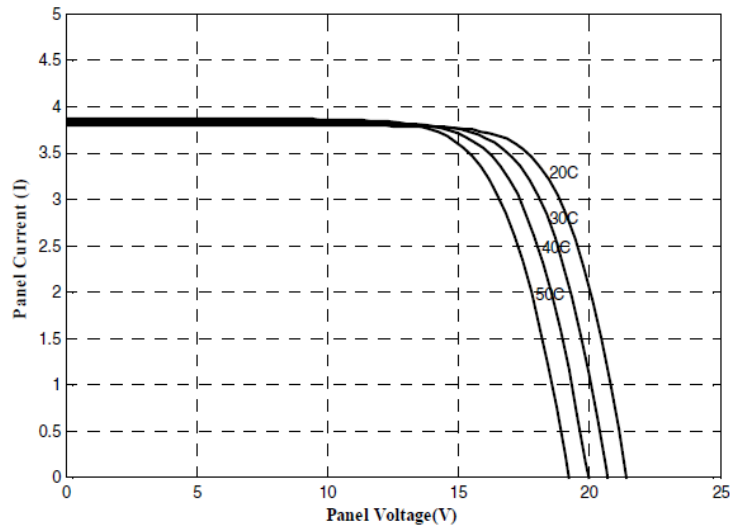

Figure 3.3: I-V curve for different temperatures.

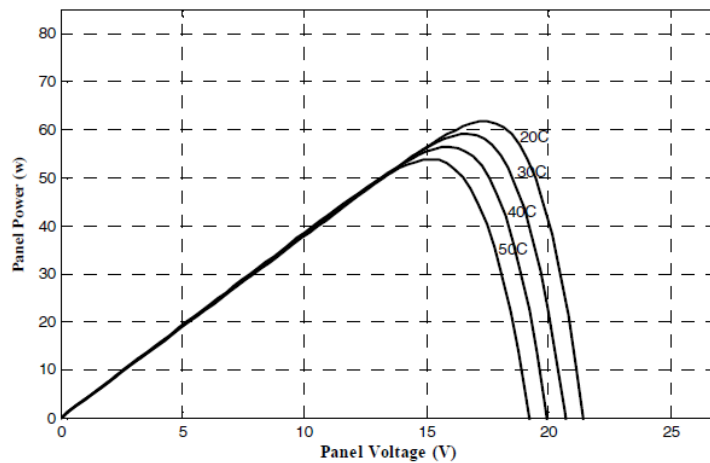

Figure 3.4: P-V curve for different temperatures.

4. Maximum Power Point Tracking (MPPT) Algorithms

The continuous operation of a PV system at MPP widely improves its efficiency, given the fluctuations in solar irradiation and environmental temperature. The implementation of MPPT algorithms ensures that maximum output power is extracted from the PV systems under all conditions of temperature and irradiation. Photovoltaic cells have a complex relationship to the maximum power they can generate in their operating environment. Cells have a single operating point for any given set of operating conditions where the cell's current (I) and voltage (V) values result in maximum power output. These values correspond to a particular load resistance which is equal to V/I as set out in Ohm's law. The power P is given by $P=V*I$. From the basic circuit theory, the power delivered from or to a device is optimized where the derivative (graphically, the slope) dI/dV of the I-V curve is equal and opposite the I/V ratio (where $dP/dV=0$). This is known as the maximum power point (MPP). Comtrollers can use multiple strategies to maximize an array's power output. Maximum Power Point trackers can implement and toggle between various algorithms depending upon array's operating conditions. The two algorithms/ techniques that have been used for determining the Maximum Operating Point in this paper are the Perturb and Observe (P&O) method and the Incremental Conductance (InC) method.

4.1 Perturb and Observe (P&O) method

Perturb and Observe (P&O) is an iterative method that tracks the Maximum Power Point of a PV system. The operation is based on regular measurements of voltage and current of the PV system to determine the output power of the system. This value of power is then compared with the previously obtained power values and the system's operating voltage is adjusted or perturbed accordingly. If the power of the PV array ($dP/dV > 0$) is increased, the control system changes the operating point of the PV array in that direction. If the power is decreased, the operating point is moved in opposite direction. This process is repeated again and again till the Maximum Power Point of the system is achieved. This method is widely used because of its simplicity and low cost in implementation. A flowchart of the mentioned method is shown;

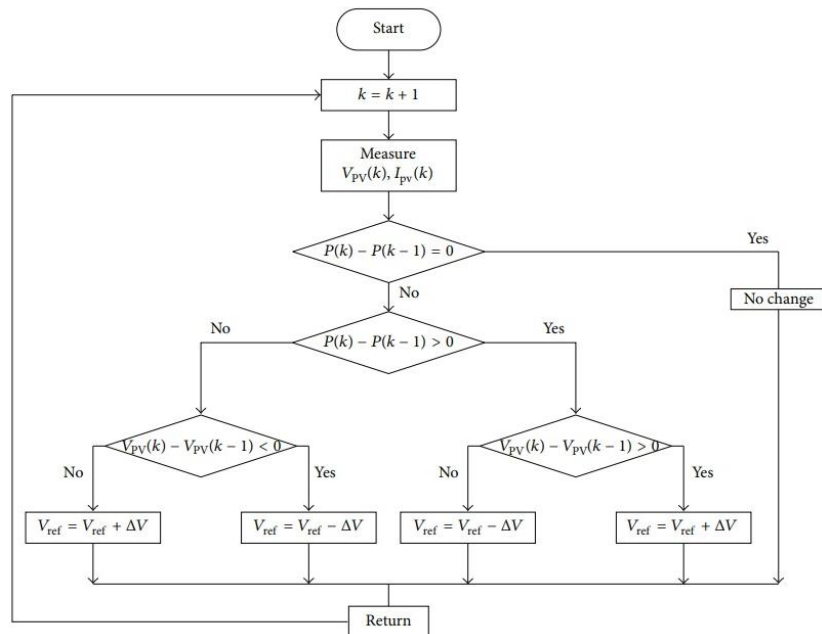

Figure 4.1: Flowchart of Perturb and Observe (P&O) MPPT algorithm.

This method was implemented in the developed model of the PV array and the result showing the effectiveness and performance of the method in tracking the Maximum Power Point of the system is shown;

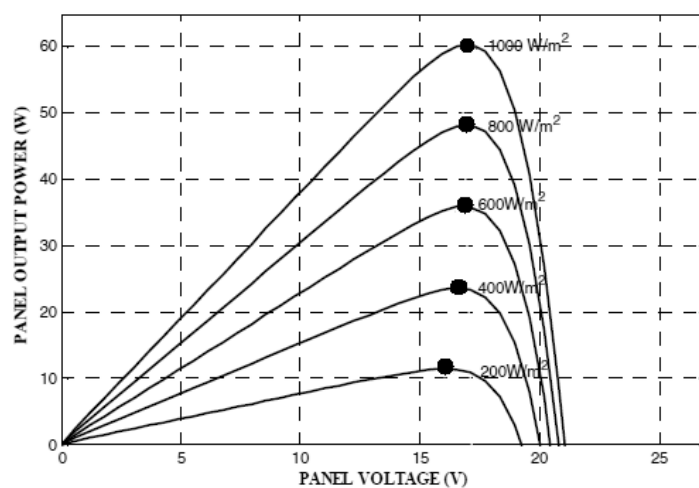

Figure 4.2: Maximum Power Point Tracking using P&O algorithm.

4.2 Incremental Conductance (InC) method

The Incremental Conductance (InC) method is based on the fact that the slope of the P-V curve of a PV system is zero when the Maximum Power Point (MPP) of the system is achieved. It is positive on the left of MPP and negative on the right. The basic equations of this method are given as under;

$$\begin{aligned} \frac{dI}{dV} &= -IV \quad \text{at Maximum Power Point (MPP)} \\ \frac{dI}{dV} &> -IV \quad \text{left of MPP} \\ \frac{dI}{dV} &< -IV \quad \text{right of MPP} \end{aligned}$$

This method however has a disadvantage that if the step size is small, the response of the system to get to MPP is slow. This method shows less oscillatory behaviour around the MPP as compared to the P&O method. A flow chart of this method is presented below;

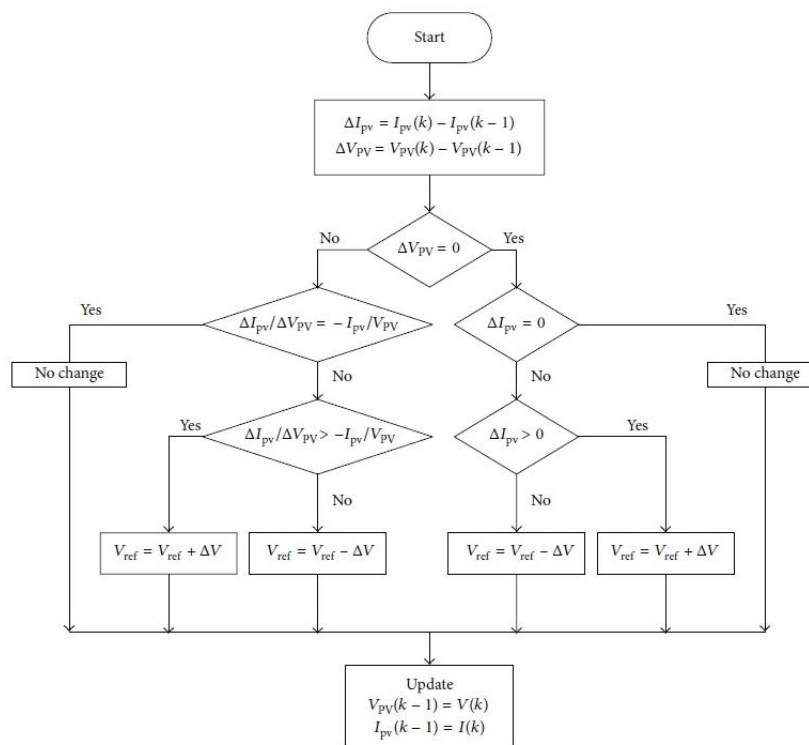

Figure 4.3: Flowchart of Incremental Conductance (InC) MPPT algorithm.

This method of MPPT was implemented in the developed model of the PV system as well and the result has been provided below;

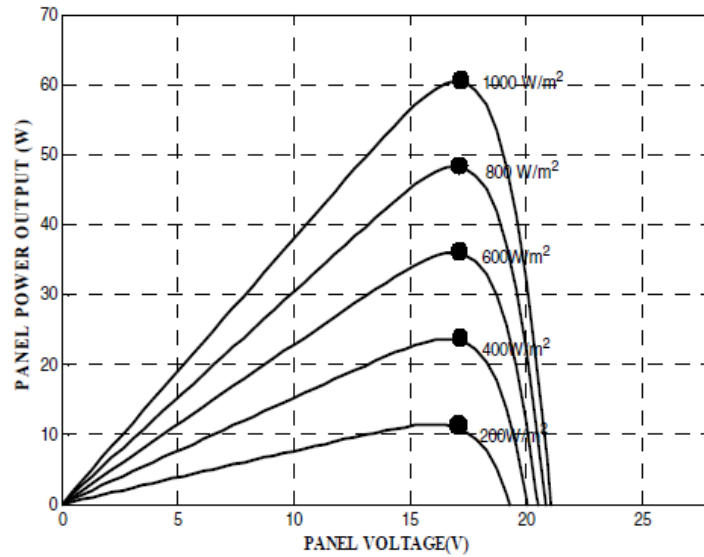

Figure 4.4: Maximum Power Point Tracking using Incremental Conductance (InC) algorithm.

4.3 Comparison of Results between P&O and InC MPPT methods

The Simulation results shown in Figure 4.2 and Figure 4.4 demonstrate the performance and efficiency of the Perturb and Observe (P&O) and Incremental Conductance (InC) algorithms in tracking the operating point at which maximum power can be coerced from the PV system. P&O's tracking performance amounts to 97% and that of InC method amounts to nearly 100%. The simulation was carried out at an ambient temperature of about 25° C and irradiation rates ranged from 200W/m² to 1000W/m² with a variable step size of 0.1 for Incremental Conductance (InC) algorithm. Further comparison has been shown below;

Table 2: Comparison of P&O and InC MPPT techniques

MPPT Techniques	Array Dependent	Analog/Digital	Periodic Tuning	Sensed Parameter	Initial Parameter Requirement	Convergence Speed	Complexity	Ability to track true maxima
P&O	No	Both	No	V	No	Varies	Low	Yes
InC	Yes	Digital	No	V, I	Yes	Varies	Medium	Yes

5. Conclusion

A generalized mathematical model which is representative of a cell, module and array has been developed and simulated in MATLAB/Simulink. The proposed model takes irradiation and temperature as input parameters and outputs the I-V and P-V characteristics under varying conditions. It can be concluded that under uniform solar irradiance, conventional MPPT algorithms provide maximum power output. But these algorithms may fail to provide MPP under rapidly changing atmospheric conditions. This can however be achieved by using MPPT methods based on stochastic and artificial intelligence like the Fuzzy Logic Controller (FLC) based MPPT methods. Such methods can improve the efficiency of electricity production to a great extent as compared to the conventional methods. This paper also presents simulation based comparative study between the Perturb and Observe (P&O) method and the Incremental Conductance (InC) method. Simulation results display that in terms of tracking performance, the InC algorithm with varying step size can accurately track the Maximum Power Point (MPP). This paper provides the reader with all the necessary information to develop a Single-Diode Model of the Photovoltaic array for analyzing and simulating the PV array. Future work can involve optimizing the energy conversion efficiency of PV system using Genetic Algorithm and Surface Area optimized Artificial Neural Networks (ANN).

References

- [1] M. G. Villalva and J. R. Gazoli, "Comprehensive Approach to Modeling and Simulation of Photovoltaic Arrays", *IEEE transactions on power electronics*, vol. 24, no. 5, May 2009.
- [2] C. C. Hua and C. M. Shen, "Study of Maximum Power Tracking Techniques and Control of DC-DC Converters for Photovoltaic Power System", *Proceedings of 29th annual IEEE Power Electronics Specialists Conference*, vol. 1, pp. 86 – 93, 1998.
- [3] L. Gil-Antonio, M. B. Saldivar-Marquez and O. Portillo-Rodriguez, "Maximum Power Point Tracking Techniques in Photovoltaic Systems: A brief review", *13th International Conference on Power Electronics (CIEP)*, Guanajuato, pp. 317 – 322, 2016.
- [4] Yamina Khelifi, "Mathematical Modeling and Simulation of Photovoltaic Solar Module in Matlab-Mathworks Environment", *International Journal of Scientific & Engineering Research*, vol. 5, issue 2, pp. 448 – 454, February 2014.
- [5] B. Subudhi and R. Pradhan, "A Comparative Study on Maximum Power Point Tracking Techniques for Photovoltaic Power Systems", *IEEE Transactions on Sustainable Energy*, vol. 4, no. 1, pp. 89 – 98, January 2013.
- [6] A. Barchowsky, J. P. Parvin, G. F. Reed, M. J. Korytowski and B. M. Grainger, "A Comparative Study of MPPT Methods for Distributed Photovoltaic Generation", *IEEE PES Innovative Smart Grid Technologies (ISGT)*, Washington, DC, pp. 1 – 7, 2012.
- [7] T. Salmi, M. Bouzguenda, A. Gastl and A. Masmoudi, "MATLAB/Simulink Based Modelling of Solar Photovoltaic Cell", *International Journal of Renewable Energy Research*, vol. 2, no.2, 2012.
- [8] A. Safari and S. Mekhilef, "Incremental Conductance MPPT method for PV Systems", *Proceedings of the 24th Canadian Conference on Electrical and Computer Engineering (CCECE)*, Ontario, Canada, pp. 345 – 347, May 2011.
- [9] A. L. Fahrenbruch and R. H. Bube, "Fundamentals of Solar Cells", London U.K, Academic Press Inc (London) Ltd. , 1983.
- [10] T. ESRAM and P. L. Chapman, "Comparison of Photovoltaic Array Maximum Power Point Tracking Techniques", *IEEE Transactions on Energy Conversion*, vol. 22, no. 2, pp. 439 – 449, June 2007.
- [11] H. L. Tsai, C. S. Tu and Y. J. Su, "Development of Generalized Photovoltaic Model using MATLAB/SIMULINK", *Proceedings of the World Congress on Engineering and Computer Science*, San-Francisco, USA, pp. 1 – 6, October 2008.
- [12] D. Sera, L. Mathe, T. Kerekes, S. V. Spataru and R. Teodorescu, "On the Perturb-and-Observe and Incremental Conductance MPPT methods for PV Systems", *IEEE Journal of Photovoltaics*, vol. 3, no. 3, pp. 1070 – 1078, July 2013.
- [13] M. Babescu, C. Sorandaru, S. Musuroi, M. Svoboda and N. V. Olarescu, "An approach on Mathematical Modelling of Photovoltaic Solar Panels", *IEEE 8th International Symposium on Applied Computational Intelligence and Informatics (SACI)*, Timisoara, pp. 239 – 243, 2013.
- [14] A. K. Gupta and R. Saxena, "Review on widely-used MPPT Techniques for PV Applications", *2016 International Conference on Innovation and Challenges in Cyber Security (ICICCS-INBUSH)*, Noida, pp. 270 – 273, 2016.